

1. **Oil Slick:**

2000 ft³ of oil spills to form a circular slick. The radius of the slick is increasing at a constant rate of 20 ft/min. How fast is the depth of the slick decreasing when the radius is 25 ft?

2. **Softball:**

A softball diamond is a square with 60 ft sides.

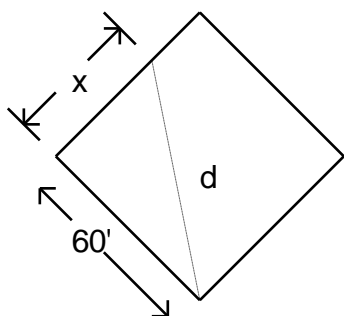

A runner runs from 2nd base to 3rd base at a rate of 10 ft/sec. How fast is the distance from the runner to home plate changing when the runner is 20 feet from 2nd base?

3. **Flight:**

An airplane traveling at a constant airspeed of 360 mph climbs at an angle of 30° to the horizontal. At one moment, the plane is 10,560 feet directly above an observer. How fast is the distance changing between the observer and the plane 3 minutes later?

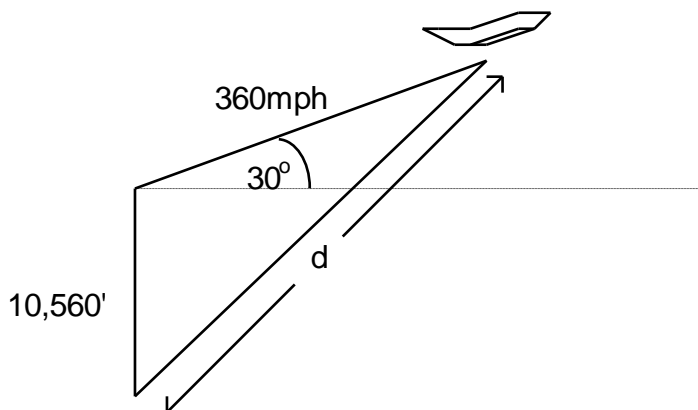

4. **Business:**

The *Flatland Technologies Company* manufactures graphing calculators with special pearl-white plastic covers that are very trendy. The demand function for these calculators is given by $p = \frac{2000}{10 + 0.1x^2}$, where p is the price per calculator, measured in dollars, and x is the number of calculators sold, measured in thousand of calculators. Determine $\frac{dx}{dp}$ when $x = 10$. Give a meaningful interpretation of your result.

5. **Biology:**

The relation between the populations of rabbits and wolves in the Bitterroot Valley of Western Montana is approximated by:

$$r = \frac{2000 - 100w}{4 + w^2}.$$

- i) If there are 20 wolves in the Bitterroot Valley, then what can you say about the population of rabbits? Is this plausible? What physical phenomena is occurring?
- ii) What is the rate of change for the population of rabbits with respect to time if there are ten wolves and the population of wolves is increasing by five wolves per year? i.e., how is the population of rabbits changing when there are ten wolves and the population of wolves is increasing by five wolves per year?

6. **Archimedes:**

My two cats, *Archimedes* and *Pythagoras*, both spot a chipmunk and lunge for it at the same time. Having been on a strict diet of fence lizards, *Archimedes* is a bit more fit than *Pythagoras*, and runs at a rate of 8 ft/s as opposed to *Pythagoras*' more sluggish 5 ft/s. *Archimedes* is initially 30 ft away from the chipmunk, while *Pythagoras* is only 20 ft away from it. They each run a straight-line path to the chipmunk, and those paths have an angle of 90° between them. How fast is the distance between *Archimedes* and *Pythagoras* changing after 2 seconds?

